

Flow Switches



Features

- Flow control designed for upto 5000 LPM with process connection upto 2"
- Applications upto 40 bar and upto 250 deg cent available
- Flow switch with options of special bellows to cater to high flows, high pressure and high temperature
- Bellows with better hysteresis for the overall flow switch accuracy
- IBR versions available
- Applicable for H2S, NACE, certified
- Switch is CCOE approved and certified for IP67
- Switch certified for group IIA/IIB, IIC
- Switch enclosure at die cast aluminium and SS available
- Versions with ATEX and FM certified available
- Durability defined on sealing and pressure and temperature application
- Improved reliability with dual opposed magnet design which provides snap action
- Applicable with various versions of MOC's depending on pressure and temperature, versions with Stainless and steel, hastelloy, monel, PTFE, PP, Titanium available

Concept and Principle of Operation

General Instruments Consortium has designed flow switches for the direct control of fluid flow in pipelines and ducts. These switches are magnetically or mechanically actuated. This is simple, reliable and economical solution to control or monitor flow in process lines. GIC offers two types of Flow Switches:

- Inline type
- Top mounted version

This is direct mounted type flow switch in pipe line. This consists of Switch assembly, Body, Bellows and Flapper. This is mounted in horizontal position. Flapper is connected to bellow assembly. When flow reaches beyond set flow the flapper moves in the direction of flow. The displacement of flapper causes actuation of the microswitch through bellow assembly. Inline type flow switch is available upto 50 NB line size and above 50 NB Top mounted is recommended. There are no vertical moving parts and is therefore maintenance free. These flow switches can be mounted in horizontal as well as vertical lines.



Technical Specifications: Table-1 Material of Construction

Displacer Flapper	SS316, SS304, SS316L, SS304L, Monel, Titanium, Hastelloy, others on request PTFE lined SS, PP lined SS, PVDF lined SS, SS316, SS304, SS316L, SS304L, Monel, Titanium, Hastelloy
Flange Switch enclosure Cable gland	SS316, SS304, SS316L, SS304L, Monel, Titanium, cast carbon steel, Hastelloy Die cast aluminium, SS304, SS316, SS316L
Bellows	Brass, PBS plastic, SS316, SS304, 316L SS316, SS316L, Monel, SS304, Phosphor Bronze

Technical Specifications: Table-2 Technical Data

Flapper length	12mm till 200mm depending on flow for control
Flapper thickness	0.15mm till 2.3 mm depending on pressure and temperature
Bellow	Double walled with 20, 30 and 40 convolutions and thickness of bellow more than the convolutions travel/length of the bellow
Process connection	½" till 2", ANSI RF, FF, 125-250AARH, DIN std DN15, 20, 25, 40, 50, socket weld, butt weld, weld neck flange in ANSI and screwed connection NPT and BSP
Float	Pressure design till 40 kg
Flange rating	max rating ANSI 600# and DN PN 100
Cable gland	Double compression, metal cable normal glands, ½" NPT F, ¾" ET, M20, PG 13.5, PG 16
Switch	SPDT, 230 VAC, 5 A or 24VDC, 0.5 A
No of cable entries	Max two
Switch enclosure	IP65, IP66, IP67
Switch enclosure	EExia IICT6, EExd IIA/IIB, EExd IIC
Switch accuracy	Max upto 1%
Switch hysteresis	Max upto 0.5% to 1%
Switch repeatability	Max upto 1%
Switch certifications	CCOE, FM, ATEX, CE (versions applicability on request)
Flange	Forged, cast versions, radiography level - 1 / 2 versions available
Flow switch weight	1.6 kg till 8 kg depending on configure of flow requirement
Temperature application	Upto 250 deg cent
Pressure application	Upto 40 kg/cm ² g
Flow in LPM in control	2 LPM till 20 LPM for ½" process connection and pipe size 8 LPM to 40 LPM for ¾" pipe size 15 LPM to 190 LPM for 1" pipe size 30 LPM to 215 LPM for 1½" pipe size 40 LPM to 360 LPM for 2" pipe size 60 LPM to 700LPM for 3" pipe size 90 LPM to 1500 LPM for 4" pipe size 125 LPM to 3000LPM for 6" pipe size 200 LPM to 4000 LPM for 8" pipe size 250 LPM to 5000LPM for 10" pipe size
Differential pressure	75mmwc till 150 mmwc

G A Drawing for assembly and mounting

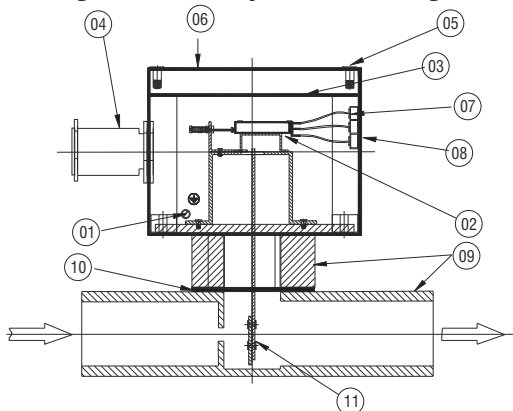

- 01 Earthing Screw
- 02 Micro Switch
- 03 Cover Gasket
- 04 Cable Entry
- 05 Cover Bolts
- 06 Enclosure Cover
- 07 Terminals
- 08 Enclosure
- 09 Body
- 10 Body Gasket
- 11 Flapper

Inline

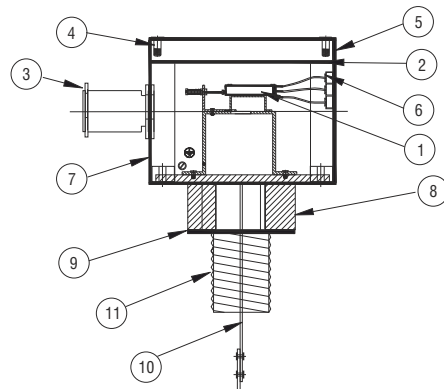

- 1 Micro Switch
- 2 Cover Gasket
- 3 Cable Entry
- 4 Cover Bolts
- 5 Enclosure Cover
- 6 Terminals
- 7 Enclosure
- 8 Enclosure
- 9 Body Gasket
- 10 Flapper
- 11 Process Conn.

Top Mounted

Ordering Information

FS IN-F01-ZA-ZC-SI-PU-MQ-Z



Type	
IN	Inline
MT	Top Mounted

Process Connection	
Flanged Connection	
F01	1/2", 150# RF
F02	3/4", 150# RF
F03	1", 150# RF
F04	1.5", 150# RF
F05	2", 150# RF
F09	1/2", 300# RF
F10	3/4", 300# RF
F11	1", 300# RF
F12	1.5", 300# RF
F13	2", 300# RF

Threaded Connection	
B04	1/2"BSP (M)
B05	3/4"BSP (M)
B06	1"BSP (M)
B07	1.5"BSP (M)
B08	2"BSP (M)
N04	1/2"NPT (M)
N05	3/4"NPT (M)
N06	1"NPT (M)
N07	1.5"NPT (M)
N08	2"NPT (M)

MOC of Body	
ZA	CS(A105)
ZB	CS(A106)
ZC	SS 304
ZD	SS 304L
ZE	SS 316
ZF	SS 316L

Cable Entry	
MQ	One
MR	Two
Z	NIL

Enclosure	
PU	Die Cast Aluminium Weatherproof to IP – 67
PV	Die Cast Aluminium Flameproof suitable to Gr. IIA / IIB
PW	Die Cast Aluminium Flameproof suitable to Gr. IIC

Microswitch	
SI	1 SPDT
SJ	2 SPDT

MOC of Flapper	
ZC	SS 304
ZD	SS 304L
ZE	SS 316
ZF	SS 316L